

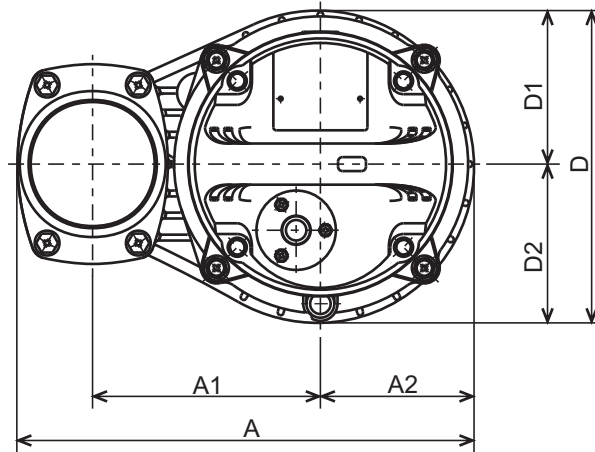

VANCS - SERIES - PU
(FRP) SEMI-VORTEX - SEWAGE & WASTEWATER PUMPS

DIMENSIONS



80PU22.2-61
80PU23.7-61

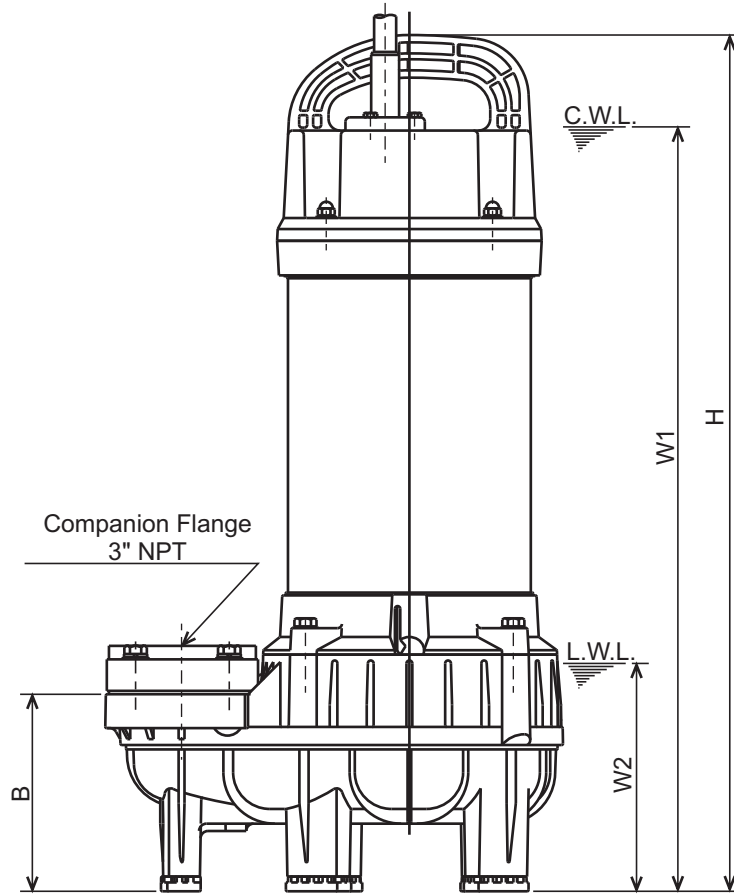

C.W.L. : Continuous running Water Level
 L.W.L. : Lowest running Water Level

DIMENSIONS:USCS (Inch)

Model	HP	NOM. SIZE	Pump & Motor								C.W.L.	L.W.L.	Wt. (lbs.)
			A	A1	A2	B	D	D1	D2	H	W1	W2	
80PU22.2-61	3	3"	12 1/4	6 1/8	4 1/8	5 1/4	8 3/8	4 1/8	4 1/4	22 15/16	20 1/2	6 1/8	48
80PU23.7-61	5	3"	12 1/4	6 1/8	4 1/8	5 1/4	8 3/8	4 1/8	4 1/4	24 5/16	21 7/8	6 1/8	59

DIMENSIONS:METRIC (mm)

Model	kW	NOM. SIZE	Pump & Motor								C.W.L.	L.W.L.	Wt. (kg)
			A	A1	A2	B	D	D1	D2	H	W1	W2	
80PU22.2-61	2.2	80	311	155	105	134	212	104	108	583	520	155	22
80PU23.7-61	3.7	80	311	155	105	134	212	104	108	618	555	155	27



VANCS-SERIES PN/PSF/PU

DIMENSIONS

TOK80PN22.2-61
 TOK80PN23.7-61
 TOK80PSF22.2-61
 TOK80PSF23.7-61
 TOK80PU22.2-61
 TOK80PU23.7-61

(Slide Rail System
 TOK2-65T)

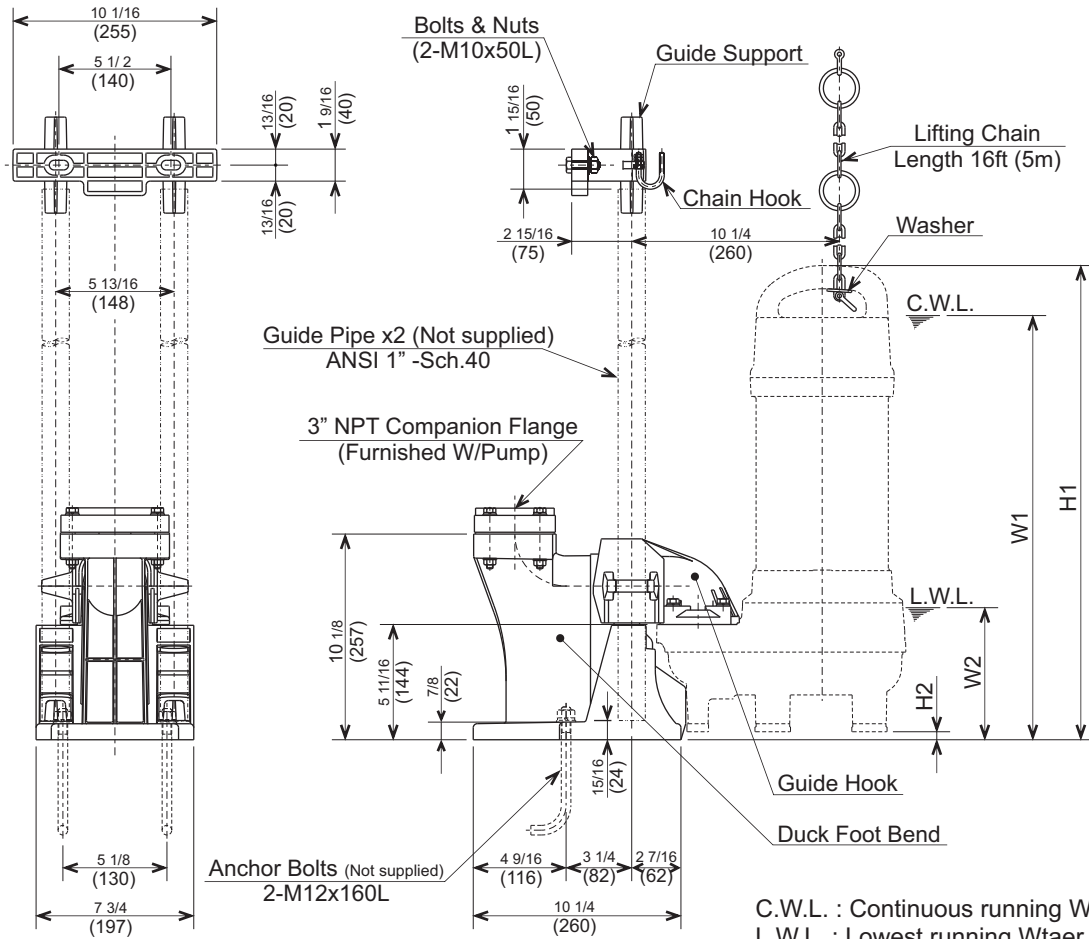
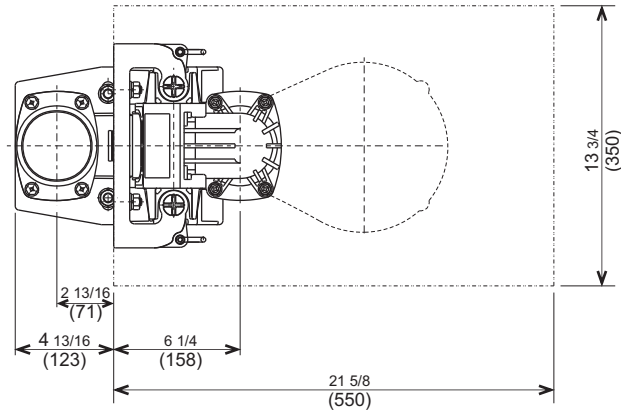

C.W.L. : Continuous running Water Level
 L.W.L. : Lowest running Water Level

Model	OUTPUT HP (kW)	NOM. SIZE inch (mm)	Dimension inch (mm)				Wt. lbs. (kg)
			H1	H2	C.W.L.	L.W.L.	
					W1	W2	
TOK80PN22.2-61	3 (2.2)	3 (80)	23 3/8 (593)	1 5/16 (34)	20 7/8 (530)	6 1/2 (165)	48 (22)
TOK80PN23.7-61	5 (3.7)	3 (80)	24 3/4 (628)	1 5/16 (34)	22 1/4 (565)	6 1/2 (165)	59 (27)
TOK80PSF22.2-61	3 (2.2)	3 (80)	23 3/8 (593)	1 5/16 (34)	20 7/8 (530)	6 1/2 (165)	48 (22)
TOK80PSF23.7-61	5 (3.7)	3 (80)	24 3/4 (628)	1 5/16 (34)	22 1/4 (565)	6 1/2 (165)	59 (27)
TOK80PU22.2-61	3 (2.2)	3 (80)	23 3/8 (593)	3/8 (10)	20 7/8 (530)	6 1/2 (165)	48 (22)
TOK80PU23.7-61	5 (3.7)	3 (80)	24 3/4 (628)	3/8 (10)	22 1/4 (565)	6 1/2 (165)	59 (27)



VANCS - SERIES - PU
(FRP) SEMI-VORTEX - SEWAGE & WASTEWATER PUMPS

PERFORMANCE
CURVE

MODEL	BORE	HP	KW	RPM	SOLIDS DIA	LIQUID	SG.	VISCOSITY	TEMP.
80PU(A/W)23.7 -61	3"/80mm	5	3.7	3495	1.81"/46mm	Water	1.0	1.123 cSt	60°F
PUMP TYPE	PHASE	VOLTAGE	AMPERAGE	HZ	STARTING METHOD	INS. CLASS			
Semi-Vortex - Sewage & Wastewater	3	208-220/460/575	14.4-13.4/6.5/5.0	60	Direct On Line	E			
CURVE No.	DATE	PHASE	VOLTAGE	AMPERAGE	HZ	STARTING METHOD	INS. CLASS		
-	-	-	-	-	-	-	-		

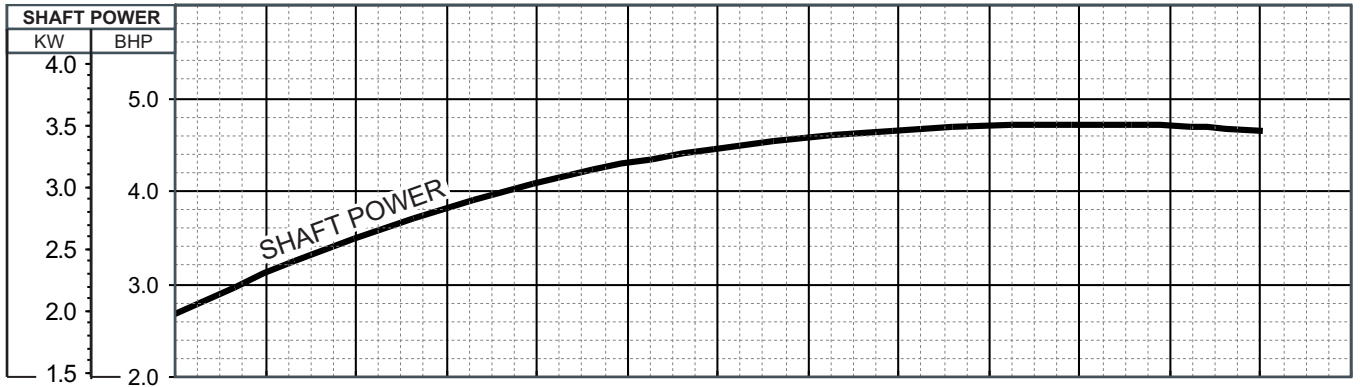
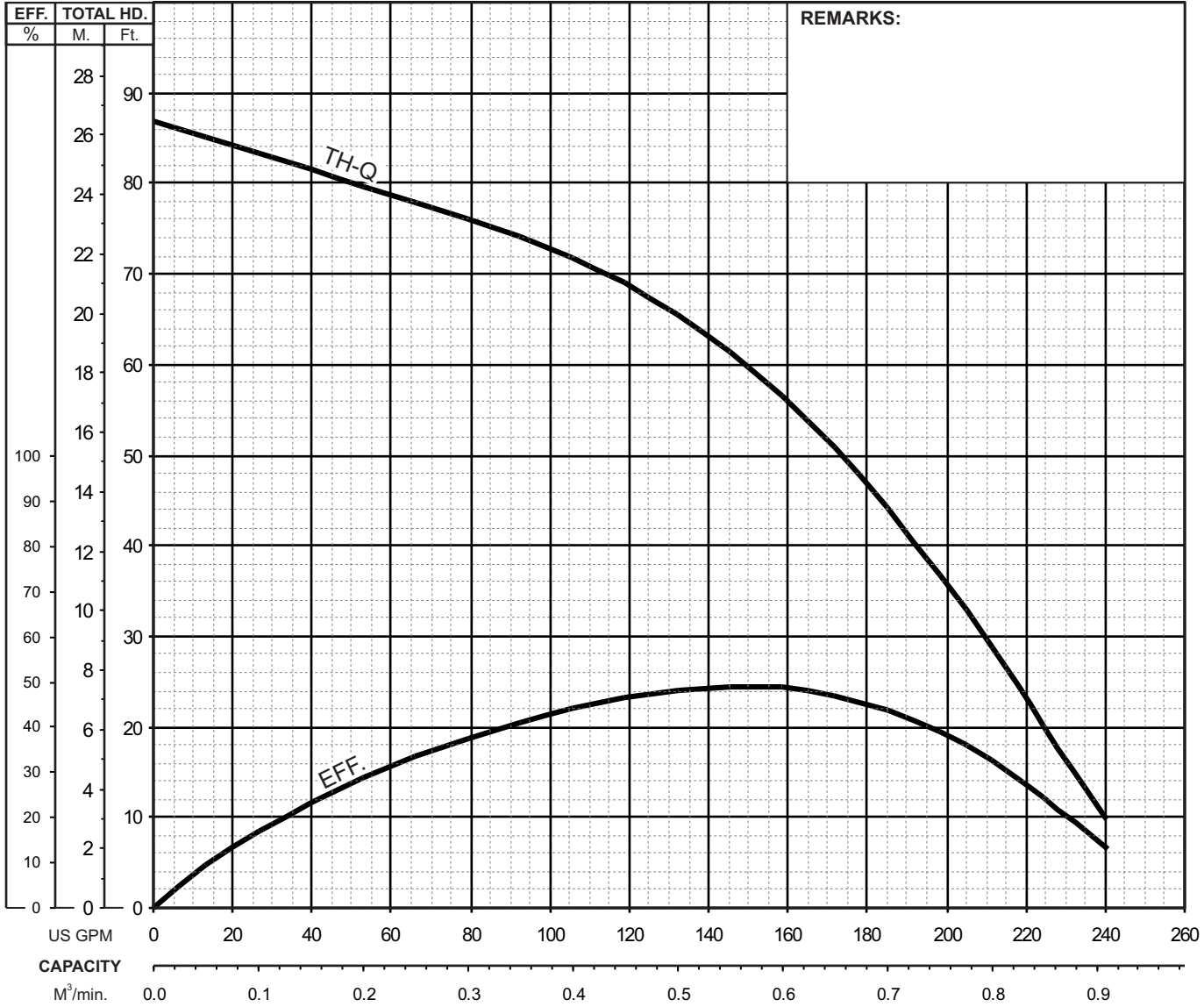



VANCS - SERIES - PU

(FRP) SEMI-VORTEX - SEWAGE & WASTEWATER PUMPS

SECTIONAL VIEW

80PU22.2-61
80PU23.7-61

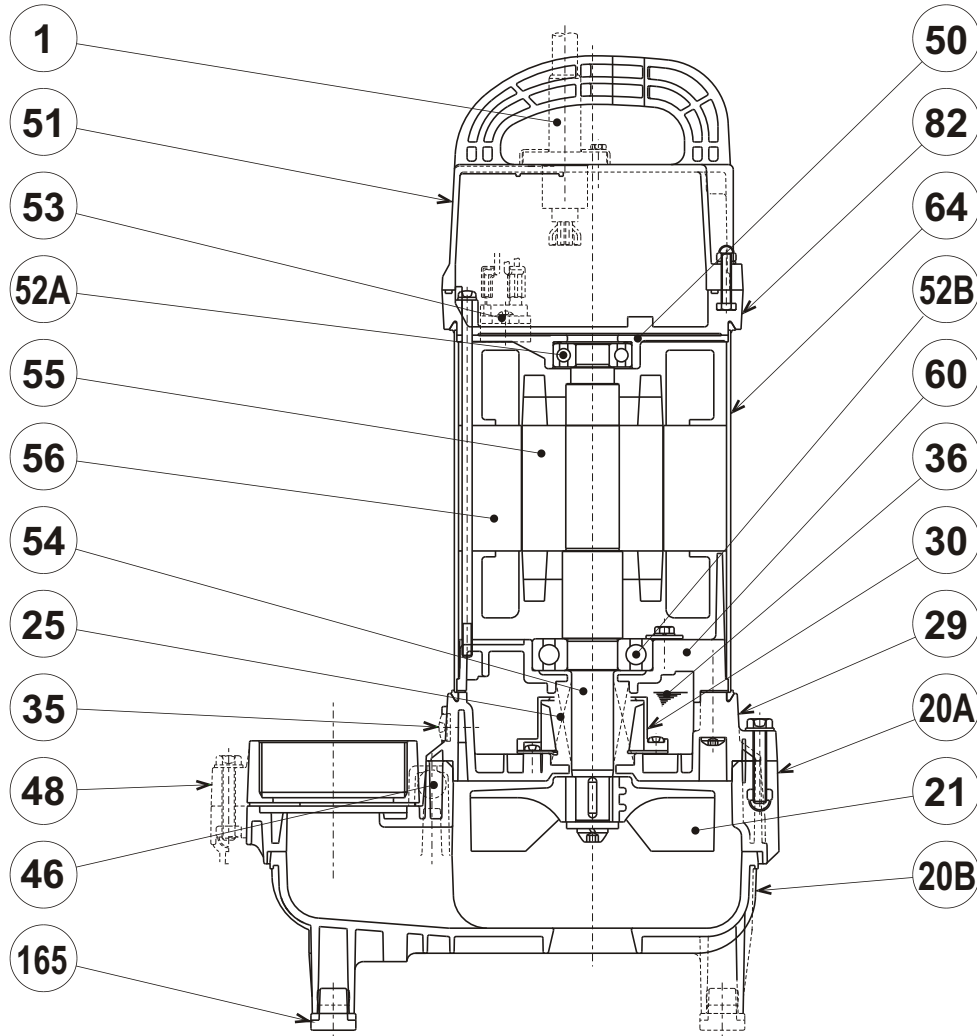

PART#	DESCRIPTION	MAIN MATERIAL / NOTE	RELATED ASTM, AISI CODE	RELATED EN CODE	QTY
1	Power Cable (80PU22.2-61)	PVC Sheath AWG14/4-32ft			1
	Power Cable (80PU23.7-61)	PVC Sheath AWG12/4-32ft			
20A	Upper Pump Casing	PA+ABS Plastic w/GF30			1
20B	Lower Pump Casing	PA+ABS Plastic w/GF30			1
21	Impeller	PPO Plastic w/GF20			1
25	Mechanical Seal	Silicon Carbide / H-25AT			1
29	Oil Casing	PPS Plastic w/(GF+MD)50			1
30	Oil Lifter	PBT Plastic w/(GF+MD)40			1
35	Oil Plug	Stainless Steel	S 30400	1.4301	1
36	Lubricant	White Mineral Oil ISO VG32			
46	Air Valve	Glass Ball			1
48	Companion Flange	PVC / NPT 3"			1
50	Motor Bracket	Aluminum Alloy Die Casting	B85 383.0	EN 1706 AC-46100	1
51	Motor Head Cover	PPS Plastic w/GF40			1
52A	Upper Bearing	#6204ZZC3			1
52B	Lower Bearing	#6306ZZC3			1
53	Motor Protector				1
54	Shaft	Stainless Steel	S 30400	1.4301	1
55	Rotor				1
56	Stator				1
60	Bearing Housing	Aluminum Alloy Die Casting	B85 383.0	EN 1706 AC-46100	1
64	Motor Housing	Stainless Steel	S 30400	1.4301	1
82	Motor Head Cover Spacer	PPS Plastic w/GF40			1
165	Rubber Cushion	Nitrile Butadiene Rubber			5

PARTS LIST		VANCS WASTEWATER PUMP				6/7/2018
ITEM	PART No.	DESCRIPTION	QTY	SIZE	MATERIAL	NOTES
1	001-001-88	Cabtyre Cable Set (32') 60Hz(USA)	1	VCT4Cx3.5mm2	BE(40)	
2	143-000-45	Tapping Screw	3	M5x25	SUS304	
3	003-000-13	Gland	1	BECE(P.C.40)	SUS304	
4	009-275-18	Compression type Terminal	4	TGNB-5.5(Insulated)	CU	
5	051-000-41	Motor Head Cover	1		Resin	
6	141-029-18	Hex.Cap Nut	4	M6	SUS304	
7	142-126-19	Plain Washer	4	M6	SUS304	
8	143-138-17	Truss Tapping Screw	2	M4x12	SWCH	
9	053-001-72	Motor Protector 208/220V-60Hz(USA)	1	KA313-GGXL110	(T)	
	053-271-11	Motor Protector 460/575V-60Hz(USA)	1	KA313-GCXL103	(T)	
10	121-001-22	Packing	1	d169xd176x3.1t(P.C.160)	NBR	*
11	143-000-48	Pan Screw	4	M6x250L(20L)	SWRM	
12	142-113-26	Plain Washer	4	M6(D=11.5)	SPC	
13	082-000-02	Head Cover Spacer	1		Resin	
14	121-001-23	Packing	1	VK(T)-22/37(A)T(W)	NBR	*
15	143-085-34	Pan Screw (w/Spring Washer)	1	M4x6	C3604	
16	009-001-09	Earth Terminal	1Set	2mm2x260L		
17	050-000-63	Motor Bracket	1		ADC	
18	056-005-90	Stator(w/M.Frame) 208/220V-60Hz(USA)	1Set			
	056-005-93	Stator(w/M.Frame) 460V-60Hz(USA)	1Set			
	056-005-94	Stator(w/M.Frame) 575V-60Hz(USA)	1Set			
19	142-000-75	Wave Washer	1	BBA0630300A0,T=0.3	SUP	
20	052-187-16	Bearing (w/O-ring)	1	AC-6204ZZC3		
21	055-001-80	Rotor	1Set	w/Bearing		
22	147-000-41	Impeller Key	1	5x5x18.5L	SUS304	
23	140-000-06	Hex.Bolt (w/Spring Washer/Plain Washer)	2	M6x12	SWCH	
24	052-109-14	Bearing	1	6306ZZC3		
25	060-001-16	Bearing Housing	1		ADC	
26	025-000-01	Mechanical Seal	1	H-25T (RoHS)	SiC	supercedes 025-255-12 and 025-000-07
27	143-070-23	Pan Screw	2	M5x6	SWRM	
28	030-143-12	Oil Lifter	1	H-25(A)(T)	Resin	
29	143-193-10	Pan Tapping Screw	2	M5x12	SWRM	
30	030-152-14	Seal Stopper	1	H-25(A)(T)	SPCC	
31	121-001-62	Packing	1	d160.4xd169.4x6.5t(P.C.144)70	NBR	* interchangeable with OLD part# 121-001-20
32	035-127-15	Oil Plug	1	M10x15	SUS304	
33	121-246-11	Packing	1	d10.3xd16x2t	PE	*
34	029-000-88	Oil Casing	1	80PUT22.2/23.7-51/61	Resin	
35	140-000-09	Hex.Bolt (w/Spring Washer)	4	M8x45	SUS304	

PARTS LIST		VANCS WASTEWATER PUMP				6/7/2018
ITEM	PART No.	DESCRIPTION	QTY	SIZE	MATERIAL	NOTES
36	143-000-46	Truss Screw (w/O-Ring)	6	M6x40(P-5,NBR)	SUS304	*
37	021-008-27	Impeller (60Hz)	1	80PU23.7-61	Resin	
	021-008-20	Impeller (50Hz)	1	80PU23.7-51	Resin	50Hz OPTION
38	142-000-71	Impeller Washer	1	d11xd31x4t	SUS304	
39	142-164-19	Spring Washer	1	M10	SUS304	
40	140-000-65	Hex. Socket Button Head Screw	1	M10x25	SUS304	
41	122-283-13	O-Ring	1	165xd3.1	NBR	*
42	140-000-09	Hex.Bolt (w/Spring Washer)	4	M8x45	SUS304	
43	048-000-75	Screwed Flange	1	NPT-3(1.5kW)	Resin	
44	121-568-12	Packing	1	d84xd98x5t	NBR	*
45	020-002-32	Pump Casing	1	80PUT22.2/3.7-51/61	Resin	
46	141-121-11	Hex.Nut	2	M8(B=12)	SUS304	
47	165-000-07	Rubber Feet	5	PU/PN/PSF21.5-52/62	NBR	
	173-002-35	Packing O-Ring Set	1Set	(Marked by *)		
10	121-001-22	Packing (Head Cover/Head Cover Spacer)	1	d169xd176x3.1t(P.C.160)	NBR	*
14	121-001-23	Packing (Head Cover Spacer/M.Frame)	1	VK(T)-22/37(A)T(W)	NBR	*
31	121-001-62	Packing (M.Frame/O.Casing)	1	d160.4xd169.4x6.5t(P.C.144)70	NBR	* interchangeable with OLD part# 121-001-20
33	121-246-11	Packing (Oil Plug)	1	d10.3xd16x2t	PE	*
36	122-003-17	O-Ring (O.Casing Bolt)	6	P-5(4.8xd1.9)	NBR	*
41	122-283-13	O-Ring (O.Casing/P.Casing)	1	165xd3.1	NBR	*
44	121-568-12	Packing (Screwed Flange)	1	d84xd98x5t	NBR	*
		Lubricant		Liquid Paraffin VG32 680ml		
		TOK2-65T		TOK2-3-1-1		

PARTS LIST		VANCS WASTEWATER PUMP				6/7/2018
ITEM	PART No.	DESCRIPTION	QTY	SIZE	MATERIAL	NOTES

EXPLODED VIEW

80PU23.7-61

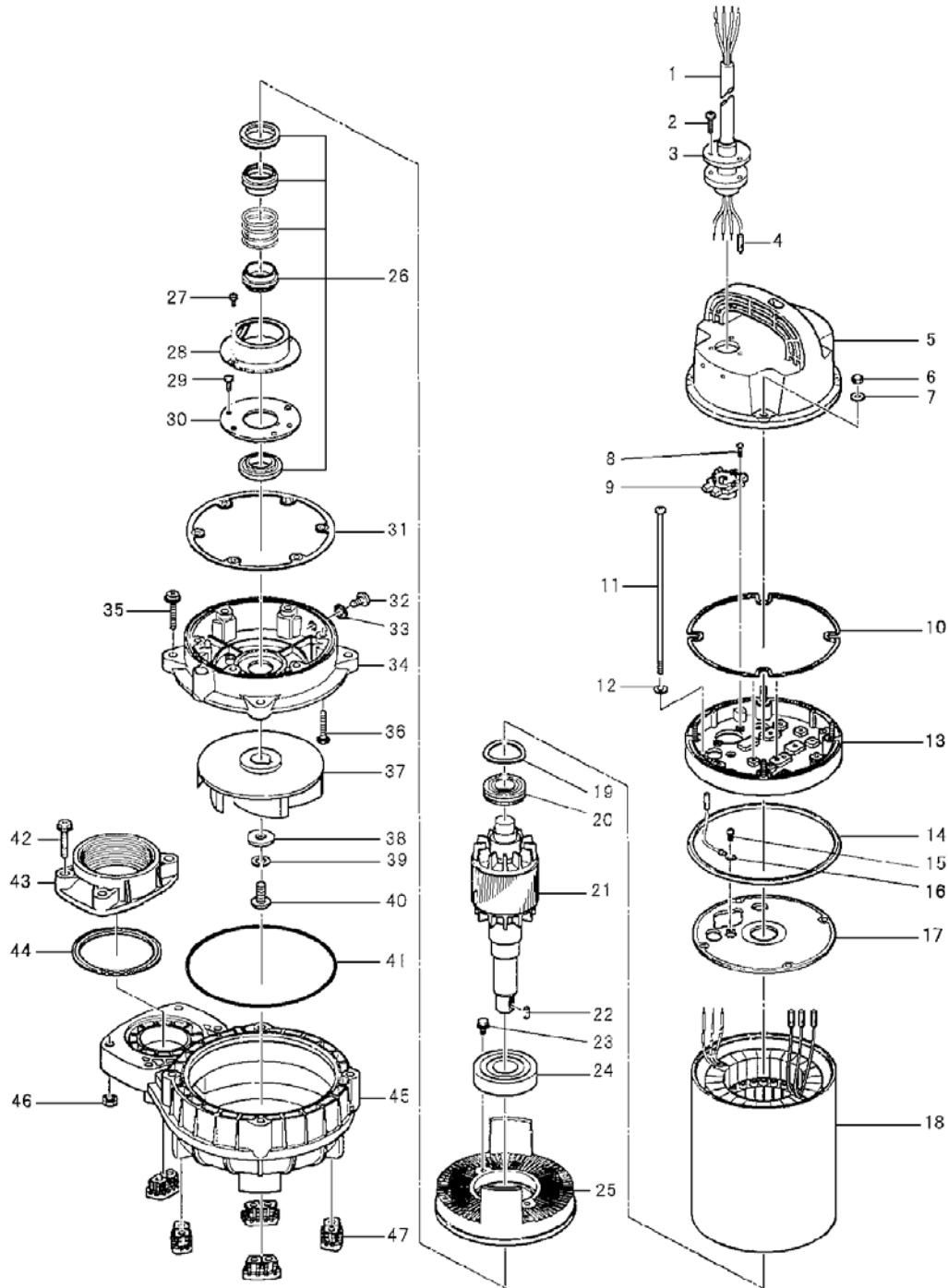

C-01175-2